

MODELL
NAW-/S

90 Grad
EINSCHRAUBBOHRUNG: T-22A

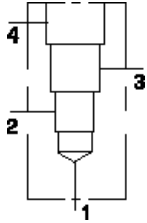

KONFIGURATION ÄNDERN

/S Modifier 65-45-12 Ductile Iron, Buna-N, Blackened

PORT HEADINGS AND SIZES

Model	Port Heading	Size
NAW	Ports 1 & 2	3/4" BSPP
NAW	Port 3	1/2" BSPP
NAW	Port 4	1/4" BSPP

BEMERKUNGEN

Important: Carefully consider the maximum system pressure. The pressure rating of the manifold is dependent on the manifold material, with the port type/size a secondary consideration. Manifolds constructed of aluminum are not rated for pressures higher than 3000 psi (210 bar), regardless of the port type/size specified.

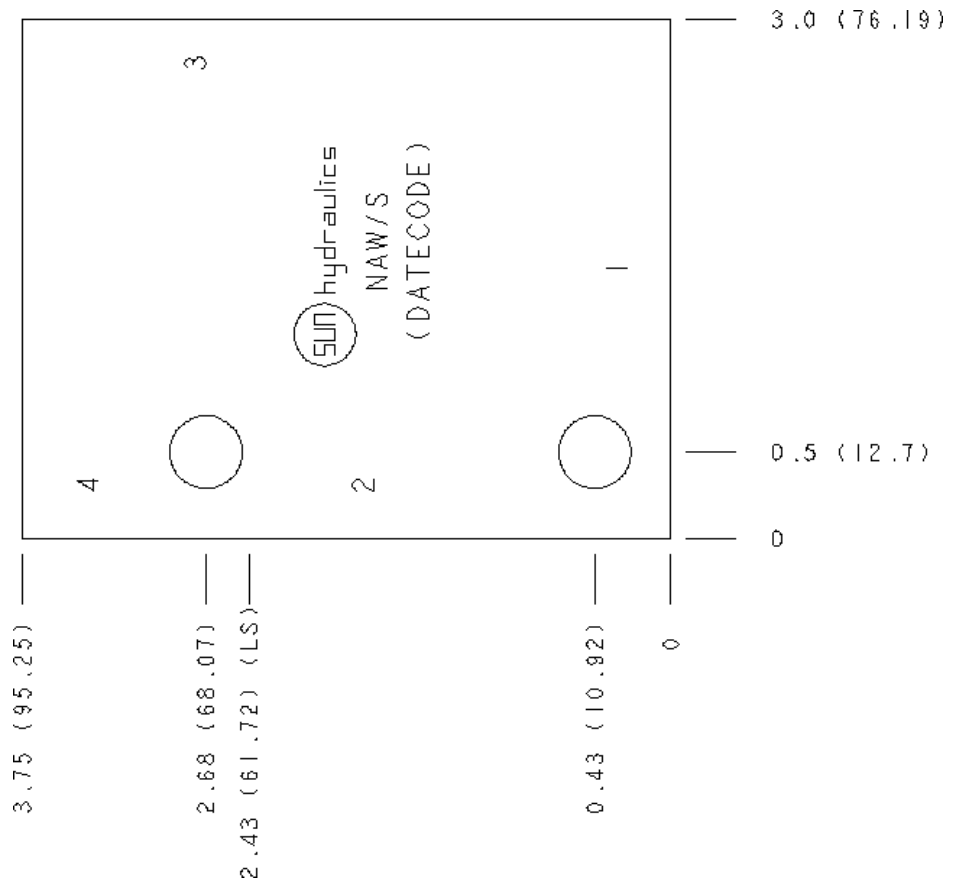

TECHNISCHE DATEN

Gehäusotyp	Rohrleitungseinbau
Lochbild	Kein
Gehäuseeigenschaften	90 Grad
Montagebohrungsdurchmesser	10,7 mm
Montagebohrungstiefe	durchgehend
Anzahl der Montagebohrungen	2
Einschraubbohrung	T-22A
Open Cavities	1
Anschlussgröße	G 3/4"
Gewicht	0.00 kg.

MANIFOLD FACES

FACE GRID

1	2	3	4
5	6	7	8
9	10	11	12

Face 2

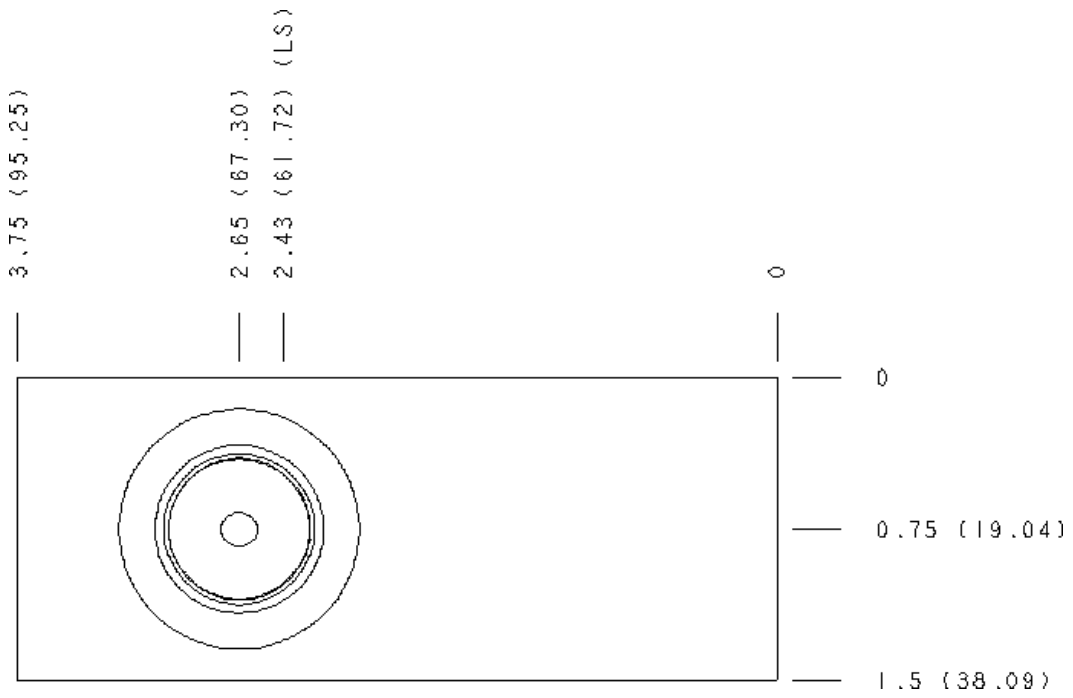

Face 5

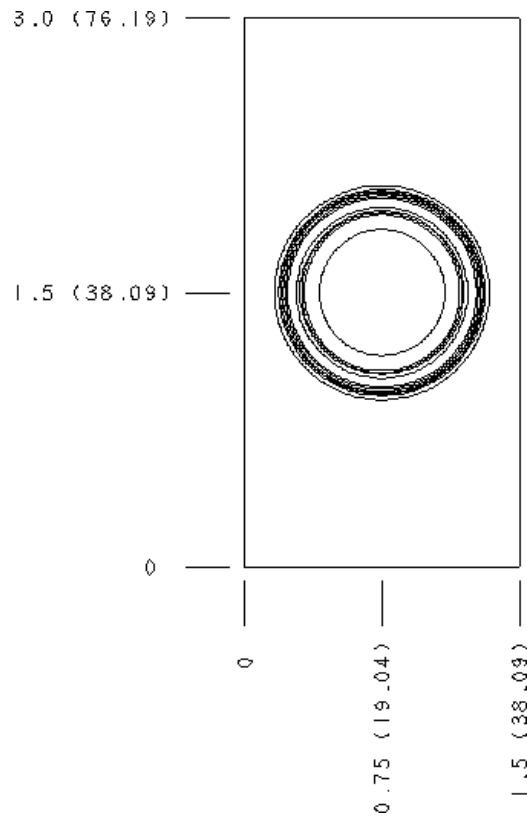

Face 6

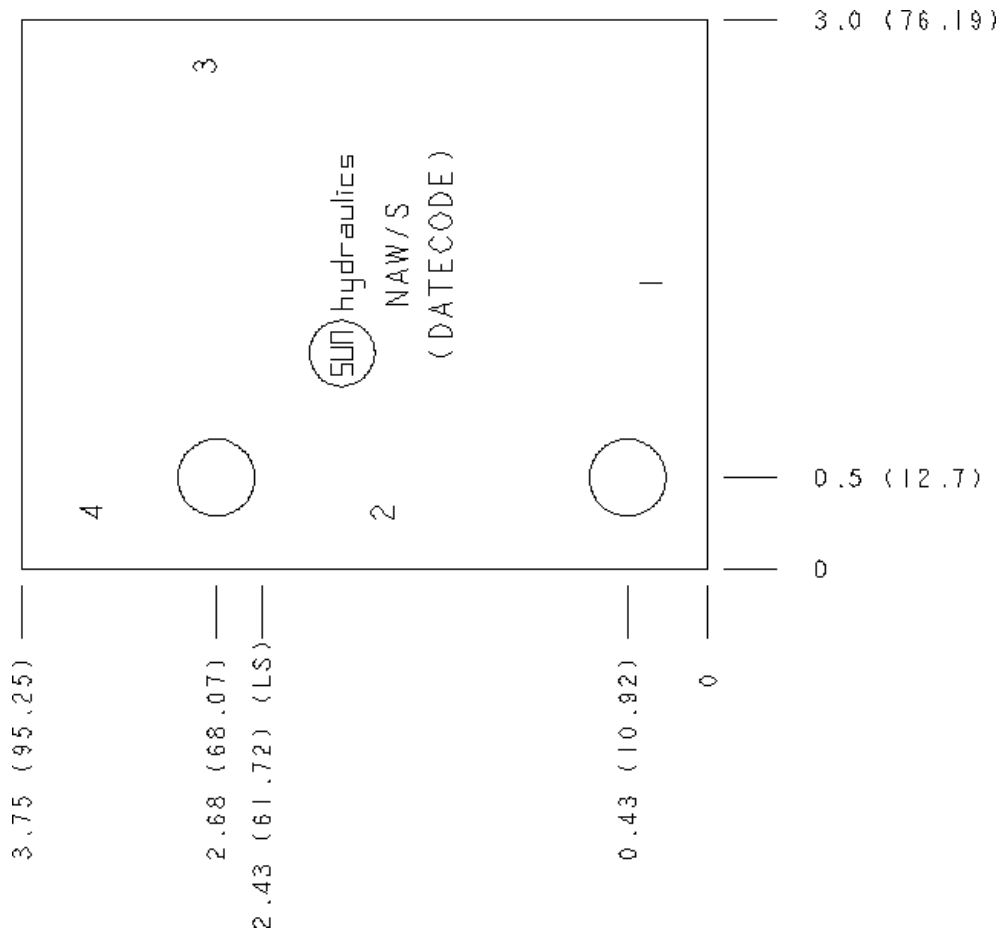

Face 7

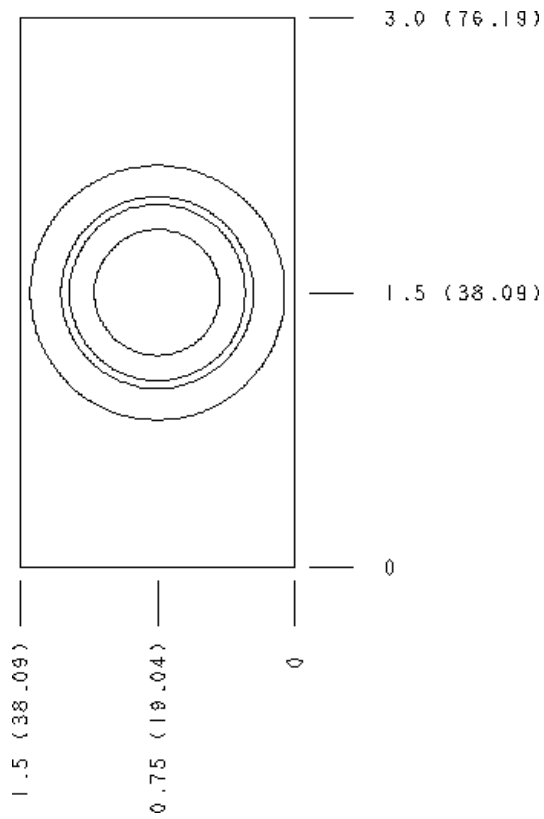

Face 10

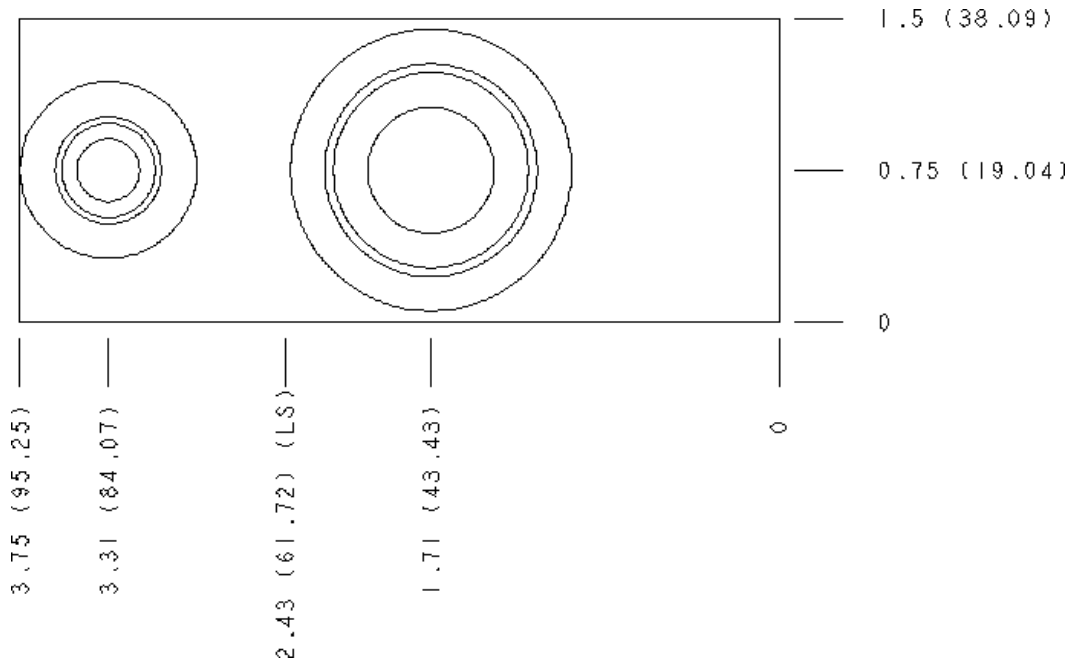

Copyright © 2002-2014 Sun Hydraulics Corporation. All rights reserved.